

mixture was quenched with saturated aqueous NH_4Cl , extracted with ether, washed with brine, dried (MgSO_4), and concentrated to give a colorless oily residue. To a stirred solution of the residue in CH_2Cl_2 (4 mL) was successively added Et_3N (0.78 mL, 5.62 mmol) and $\text{CH}_3\text{SO}_2\text{Cl}$ (0.11 mL, 1.41 mmol) at -78°C . The reaction mixture was stirred for 10 min at the same temperature, and then for 20 min at 0°C . The reaction mixture was quenched with ice-water, extracted with ether, washed with brine, dried (MgSO_4), and concentrated. The residue was purified by silica gel column chromatography (hexane-ether, 10:1) to give **21** (196 mg, 88%) in a ratio of 1(*E*):30(*Z*) as a colorless oil: for the *Z*-isomer $^1\text{H NMR}$ (CDCl_3) δ 0.06 (s, 12 H), 0.88, 0.92 (s and s, total 18 H), 1.10-1.88 (m, 4 H), 2.00-3.30 (m, 7 H), 3.64 (d, $J = 5.0$ Hz, 1 H), 3.70 (d, $J = 3.5$ Hz, 1 H), 3.92 (ddd, $J = 6.5, 8.5, 8.5$ Hz, 1 H), 6.02 (d, $J = 2.0$ Hz, 1 H), 6.30 (t, $J = 7.5$ Hz, 1 H); IR (neat) 2250, 1460 cm^{-1} ; MS (m/z), 460 ($\text{M}^+ - \text{Me}$), 418 ($\text{M}^+ - ^i\text{Bu}$, base peak), 286, 212, 186, 147, 117, 73; HRMS ($\text{M}^+ - ^i\text{Bu}$) calcd for $\text{C}_{23}\text{H}_{40}\text{NO}_2\text{Si}_2$ 418.2597, found 418.2568; for the *E*-isomer $^1\text{H NMR}$ (CDCl_3) δ 0.03, 0.06 (s and s, total 12 H), 0.84, 0.90 (s and s, total 18 H), 0.96 (t, $J = 8.0$ Hz, 3 H), 1.08-1.80 (m, 4 H), 1.96-2.90 (m, 7 H), 3.10 (m, 1 H), 3.62 (d, $J = 5.5$ Hz, 1 H), 3.63 (d, $J = 4.0$ Hz, 1 H), 3.91 (ddd, $J = 7.0, 8.5, 8.5$ Hz, 1 H), 6.02 (br s, 1 H), 6.10 (t, $J = 7.8$ Hz, 1 H); IR (neat) 2250, 1460 cm^{-1} ; MS (m/z), 460 ($\text{M}^+ - \text{Me}$), 418 ($\text{M}^+ - ^i\text{Bu}$, base peak), 286, 147, 73; HRMS ($\text{M}^+ - ^i\text{Bu}$) calcd for $\text{C}_{23}\text{H}_{40}\text{NO}_2\text{Si}_2$ 418.2597, found 418.2574.

(1*S*,5*S*,6*S*,7*R*)-6-(((*tert*-Butyldimethylsilyloxy)methyl)-7-((*tert*-

butyldimethylsilyloxy)-(E)-3-(1-cyanopentylidene)bicyclo[3.3.0]octane (**22a**) and its *Z*-Isomer (**22b**). A suspension of 10% Pd-C (5 mg, 10 mol %) in toluene (0.5 mL) was stirred at 23°C for 0.5 h under 1 atm of H_2 pressure. To a cooled (-40°C) suspension was added **21** (22 mg, 0.05 mol, *E:Z* = 1:30) in toluene (1.5 mL), and the mixture was stirred for 4.5 h at -40°C . The reaction mixture was filtered through silica gel and washed with ether. The combined filtrates were concentrated. The product was purified by silica gel column chromatography (hexane-ether, 25:1) to give **22** (15 mg, 66%, **22a:22b** = 10:1)^{11a} as a colorless oil: for **22a**, $^1\text{H NMR}$ (CDCl_3) δ 0.04, 0.05 (s and s, total 12 H), 0.87, 0.89 (s and s, total 18 H), 0.92 (t, $J = 7.0$ Hz, 3 H), 1.35 (m, 3 H), 1.52 (m, 3 H), 2.15 (m, 3 H), 2.23-2.65 (m, 5 H), 2.82 (m, 1 H), 3.55 (d, $J = 6.0, 10.0$ Hz, 1 H), 3.64 (d, $J = 6.0, 10.0$ Hz, 1 H), 3.91 (ddd, each $J = 7.0$ Hz, 1 H); IR (neat) 2250, 1480 cm^{-1} ; MS (m/z), 477 (M^+), 462 ($\text{M}^+ - \text{Me}$), 420 ($\text{M}^+ - ^i\text{Bu}$), 288, 214, 189, 147, 133, 73; HRMS (M^+) calcd for $\text{C}_{27}\text{H}_{51}\text{NO}_2\text{Si}_2$ 477.3458, found 477.3443; for **22b** $^1\text{H NMR}$ (CDCl_3) δ 0.04, 0.05 (s and s, 12 H), 0.87, 0.89 (s and s, 18 H), 0.92 (t, $J = 7.5$ Hz, 3 H), 1.33 (m, 3 H), 1.52 (m, 3 H), 2.15 (m, 3 H), 2.25-2.85 (m, 6 H), 3.60 (d, $J = 5.0$ Hz, 2 H), 3.99 (ddd, each $J = 7.0$ Hz, 1 H); IR (neat) 2250, 1480 cm^{-1} ; MS (m/z), 477 (M^+), 462 ($\text{M}^+ - \text{Me}$), 420 ($\text{M}^+ - ^i\text{Bu}$), 288, 214, 189, 147, 133, 73; HRMS (M^+) calcd for $\text{C}_{27}\text{H}_{51}\text{NO}_2\text{Si}_2$ 477.3458, found 477.3476.

Acknowledgment. We thank Yumiko Misu of our university for her help with the NMR studies.

Novel Sponge-Derived Amino Acids. 5.¹ Structures, Stereochemistry, and Synthesis of Several New Heterocycles

Madeline Adamczeski, Emilio Quiñoa, and Phillip Crews*

Contribution from the Department of Chemistry and Institute for Marine Sciences, University of California, Santa Cruz, California 95064. Received March 9, 1988.

Revised Manuscript Received August 25, 1988

Abstract: This paper reports the complete amino acid chemistry of an undescribed Jaspidae sponge, collected annually in the Benga lagoon of the Fiji Islands during the period from 1984 to 1987. Five different amino acid types are represented among its constituents and they include the bengamides (six compounds), isobengamide E, bengazoles (A and B), a diketopiperazine *cyclo(L-trans-(4-hydroxyprolinyl)-L-phenylalanine)*, and *N*-acetyl-L-phenylalanine methyl ester. The structures and stereochemical features of the bengamides were established by relying on analogies to bengamides A and B, along with insights gained by extensive spectroscopic and chemical degradation of isobengamide E and bengamide E. The chirality of the substituted ϵ -caprolactam ring of the bengamides was established as 10*S* and 13*S* by a combination of molecular mechanics calculations and hydrolysis of isobengamide E and bengamide E fragmentation products to obtain L-lysine hydrochloride. The relative stereochemistry of the 2(*R**)-methoxy-3(*R**)-4(*S**)-5(*R**)-trihydroxy-8-methylnon-6(*E*)-enoyl side chain of the bengamides was based on analysis of $^1\text{H NMR}$ J values of cyclized products. The bengazole structures have been previously established, and the structures of the remaining two amino acids were verified by synthesis. Biogenetic pathways are suggested for each of the most novel amino acid types.

The study of nitrogen-containing heterocycles from Choristid sponges is a subject to which we and others are now devoting attention. The taxa from three families within this order, Jaspidae, Geodiidae, and Kallapididae, seem especially important because their multifarious natural products are almost always accompanied by exciting biological activity.² A few years ago we began a study of an encrusting, globular, orange, undescribed Jaspidae sponge

that was prominent in the coral reef communities throughout Fiji. Our early collections had extracts with potent anthelmintic activity that afforded atypical amino acid derivatives, bengamides A and B,³ as the only active constituents obtainable in large enough amounts to permit structural characterization. Faint $^{13}\text{C NMR}$ resonances between 40-60 and 150-180 ppm could be observed in anthelmintic-active solvent-partition fractions which intimated that other bioactive amino acids might be present.

During the past 2 years we have obtained this sponge from many Fiji locations. By contrast, our pursuit of this sponge from locations outside of Fiji were unsuccessful as it could not be located in nearby south Pacific areas ranging from Tonga to Vanuatu to the Solomon Islands. It now seems appropriate to give a complete account of the remarkable chemistry of this sponge because it ranges from bengamides A (1) and B (2)³ to bengamides C-F (3-6), isobengamide E (7), bengazoles A (8) and B (9)⁴, di-

(1) Previous papers in this series are part 4, ref 17; part 3, ref 4; part 2, ref 3; and part 1, ref 2a.

(2) Recent examples of novel cytotoxins are jaspakinolide [= jaspamide] from *Jaspis johnstoni* [Jaspidae]: (a) Crews, P.; Manes, L. V.; Boehler, M. *Tetrahedron Lett.* **1986**, 27, 2797. (b) Zabriskie, T. M.; Klocke, J. A.; Ireland, C. M.; Marcus, A. H.; Molinski, T. F.; Faulkner, D. J.; Xu, C.; Clardy, J. *J. Am. Chem. Soc.* **1986**, 108, 3123. (c) Braekman, J. C.; Daloz, D.; Moussaiaux, J. *Nat. Prod.* **1987**, 50, 994. Calyculin A from *Discodermia calyx* [Kallapsidae]: (d) Kato, Y.; Fusetani, N.; Matsunaga, S.; Hashimoto, K.; Fujita, S.; Furuya, T. *J. Am. Chem. Soc.* **1986**, 108, 2780. The geodiolides from *Geodia* sp. [Geodiidae]: (e) Pettit, G. R.; Rideout, J. A.; Hasler, J. A. *J. Nat. Prod.* **1981**, 33, 588. (f) Chan, W. R.; Tinto, W. F.; Manchand, P. S.; Todaro, L. J. *J. Org. Chem.* **1987**, 52, 3091. The discodermis from *Discodermia kiiensis* [Geodiidae]: (g) Matsunaga, S.; Fusetani, N.; Konosu, S. *Tetrahedron Lett.* **1985**, 26, 855.

(3) Quiñoa, E.; Adamczeski, M.; Crews, P. *J. Org. Chem.* **1986**, 51, 4494.

(4) Adamczeski, M.; Quiñoa, E.; Crews, P. *J. Am. Chem. Soc.* **1988**, 110, 1598.

ketopiperazine *cyclo(L-trans-(4-hydroxyprolinyl)-L-Phe)* (**10**), and *N*-acetyl-*L*-phenylalanine methyl ester (**11**). Two additional

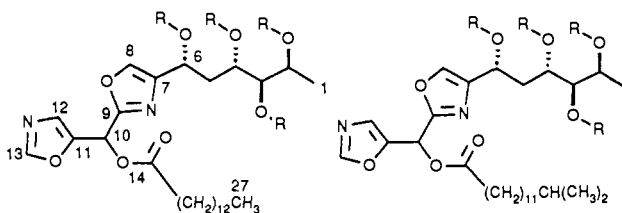

8 R = H (Bengazole A)

9 R = H (Bengazole B)

bengamides, **14** and **15**, were also isolated but they are artifacts of the acid-catalyzed fragmentation from bengamides C and D.

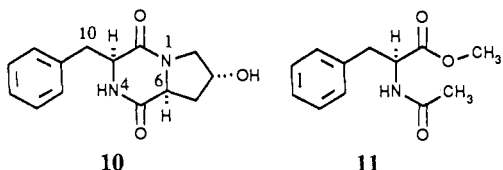

10

11

The freshly collected sponge was immersed in CH_3OH and a viscous crude oil (14.07 g) was obtained. The isolation work was begun after executing the standard solvent-partitioning procedure of placing the crude extract in aqueous methanol and washing this successively with hexanes, CCl_4 , and CH_2Cl_2 . The composition of the extract from the 1985 collection was rather simple, as bengamides A and B were the major components of both the CCl_4 and CH_2Cl_2 partition fractions. By contrast, the 1986 collection was extremely complex and an intricate approach was needed to successfully separate the components from the hexane, CCl_4 , and CH_2Cl_2 partition fractions of the crude extract as summarized in Chart I (see supplementary material). Highlights include the following: the hexane partition fraction (coded as A) provided lactone **13**; the CCl_4 partition fraction (coded as B) provided **1**, **2**, **4**–**12**, **16**, and **18**; and the CH_2Cl_2 partition fraction (coded as C) provided **3**, **5**, **6**, **8**–**10**, **17**, and **18**.

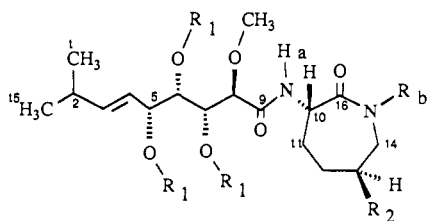

Bengamide	R ₁	R ₂	R ₃
A (1)	H	$-\text{O}_2\text{C}(\text{CH}_2)_{12}\text{CH}_3$	H
B (2)	H	$-\text{O}_2\text{C}(\text{CH}_2)_{12}\text{CH}_3$	CH_3
C (3)	H		H
D (4)	H		CH_3
E (5)	H	H	H
F (6)	H	H	CH_3
14	H	OH	H
15	H	OH	CH_3
16	Ac	OAc	H
17	Ac	OAc	CH_3
20	Ac	$-\text{O}_2\text{C}(\text{CH}_2)_{12}\text{CH}_3$	H
21	Ac	$-\text{O}_2\text{C}(\text{CH}_2)_{12}\text{CH}_3$	CH_3
22	Ac	H	H
23	Ac	H	CH_3

The structure of isobengamide E (**7**) will be described first since the strategies to elucidate its structure and stereochemistry were utilized to complete the stereochemical assignments for bengamides

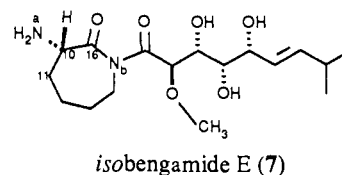

isobengamide E (**7**)

A (**1**) and B (**2**) and to establish the structures of other new bengamide derivatives. The initial attributes of **7**, $\text{C}_{17}\text{H}_{30}\text{N}_2\text{O}_6$ deduced by CIMS, EIMS ($M^+ + H = 359$), and a ^{13}C APT NMR spectrum, were established from spectroscopic and chemical properties along with comparisons to those of bengamides A (**1**) and B (**2**).³ The unsaturation elements of **7** were similar to those of **1** and **2**, as indicated by the very low field ^{13}C NMR peaks, which included those from two carbonyls (174.1, s, 174.2, s) and the side-chain *E* double bond (140.2, d, 125.7, d; 5.71, dd, $J = 15.4$ and 6.5 Hz; 5.40, dd, $J = 15.4$ and 7.2 Hz). The 2-methoxy-3,4,5-trihydroxy-8-methyl-non-6(*E*)-enoyl group, also present in **1**, was recognized in **7** by connectivities established in ^1H - ^1H and ^1H - ^{13}C COSY NMR spectra. Furthermore, this same COSY NMR data established that the ϵ -caprolactam in **7** was also similar to that in bengamides A (**1**) and B (**2**), but the $\text{CH}(\text{O})$ of **1** at $\delta = 70.9$ (C-13) was shifted upfield in **7** ($\delta \approx 27$, t), indicating that the amino acid present in isobengamide E was lysine and not δ -hydroxylysine. The two nitrogens and their associated hydrogens of **7** could be designated as N_2H_2 by comparing the molecular formula to the $\text{C}_{17}\text{H}_{25}$ count obtained from the APT spectrum and the presence of OH groups at C-5, C-6, and C-7. At this point there were two alternative structures, **5** and **7**, that were consistent with the accumulated data. An absolute way to distinguish between these possibilities was provided by concurrent isolation of bengamide E (**5**), also of formula $\text{C}_{17}\text{H}_{30}\text{N}_2\text{O}_6$, and bengamide F (**6**).

The similar NMR properties of bengamide E (**5**), bengamide A (**1**), and bengamide B (**2**) were diagnostic of the identical environment of the N_2H_2 atoms, as two secondary amides, in each of these compounds. The relevant ^1H NMR shifts were at H-10 [(CDCl_3) **1**, $\delta = 4.60$; **2**, $\delta = 4.64$; **5**, $\delta = 4.53$; (CD_3OD) **2**, $\delta = 4.68$]² and H-11 [(CDCl_3) **1**, $\delta = 2.15$, 1.75; **2**, $\delta = 2.10$, 1.57; **5**, $\delta = 1.99$, 1.57; (CD_3OD) **2**, $\delta = 1.99$, 1.55], and the average chemical shift difference at H-11/11' was 0.45 ± 0.08 ppm. The additional relatedness of bengamides E (**5**) and F (**6**) to the bengamides A (**1**) and B (**2**) was established by key ^1H - ^{13}C COSY NMR resonances for both the ϵ -caprolactam ring and the branched C-10 side chain. With bengamide A as a model, the especially diagnostic signals of C-10/H-10 (δ 51.5, d/4.60, m), C-11/H-11 (28.9, t/2.15, m, 1.75, m), C-8/H-8 (81.3, d/3.80, m), and C-2/H-2 (30.9, d/2.29, m) could all be located in bengamides E and F as seen in Tables I and II. The major difference between bengamides A and B, and E (**5**) and F (**6**) was the absence of the ester substituent at C-13 because in the latter two these carbon resonances were respectively $\delta = 28.7$ and 26.6. Furthermore, ^1H - ^{13}C COSY ($J = 9$ Hz) spectra (CDCl_3) for **5** verified the attachment of the C-10 side chain to the N-a, which is further attached to C-10 because a strong correlation was observed from H-a to C-9 ($\delta = 171.7$), and correlations were also observed from H-11 and H-11' to C-16 ($\delta = 175.2$). Strong ^1H - ^{13}C COSY ($J = 9$ Hz, CDCl_3) correlations were also observed to one of the carbonyls of **6**, including from H-11/-11', NMe-b, and H-14/14' to C-16 ($\delta = 172.3$). Bengamides E and F behaved analogously to A and B when subjected to acetylation, and their respective acetates **22** and **23** had properties that were similar to those of acetates **20** and **21**, which were obtained from bengamides A and B (Tables I and II). Especially important was that the latter two bengamides were examined by ^1H - ^1H COSY NMR to verify the location of the branched side-chain OCH_3 substituent proposed at C-8.

Some key NMR features summarized above were different in isobengamide E (**7**) as follows: H-10 [(CD_3OD) $\delta = 4.13$] and H-11 [(CD_3OD) $\delta = 1.72$, 1.78], and the chemical shift difference at H-11/11' was 0.06 ppm. Compound **7** was insoluble in CHCl_3 , whereas **1** and **5** exhibited identical solubility properties, as both

were easily dissolvable in CHCl_3 and in MeOH. Also in contrast to the behavior of the latter was the behavior of isobengamide E under acetylation conditions, as this afforded *N*-acetylcyclolysine (**27**) accompanied by a 9:1 mixture of the diacetylated lactone **18** and its dehydro analogue, **19**. The facile acyl cleavage assisted

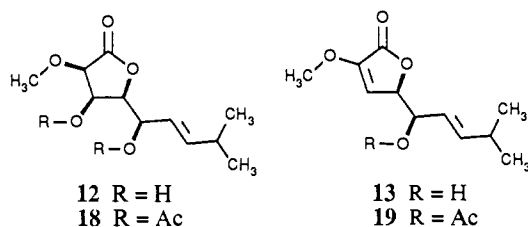

by the δ -hydroxy group, resulting in intramolecular esterification⁵ for **7** and not **5** under acetylation conditions (or with catalytic toluenesulfonic acid, TSA), is consistent with the better leaving group ability expected for the imide type nitrogen of the former as compared to that of the amide type nitrogen of the latter. Consequently, isobengamide E was assigned as gross structure **7** with primary amine and tertiary imide type nitrogens.

The results of several additional chemical transformations are summarized in Scheme I. Analysis of the derivatives which we obtained further supported the proposed structure of **7** and enabled the assignment of the absolute stereochemistry of the lysine subunit as well as the relative stereochemistry of the C-10 side chain. Treatment of **7** with 2,2-dimethoxypropane (DMP) and catalytic TSA in acetone afforded cyclolysine (**26**), along with a 4:1 mixture

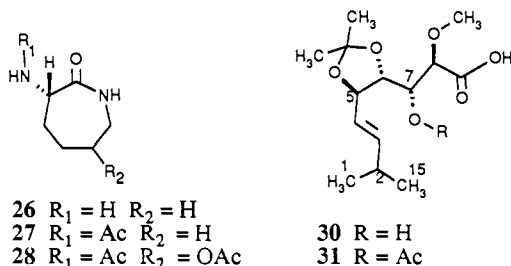
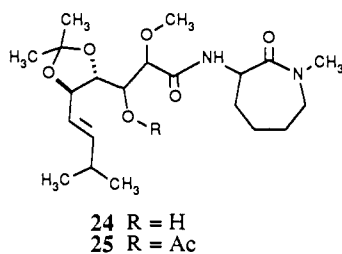
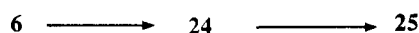

of the dioxolane acid **30** and the bicyclic lactone **32** (Chart III). The position of the dioxolane ring in **30** was conclusively deduced by its further transformation to the corresponding acetate **31**, in which proton connectivities were established by ^1H - ^1H COSY NMR. The fragmentation product **27**, obtained from **7** during acetylation, was subjected to acidic hydrolysis, yielding lysine as its cationic salt, whose rotation ($[\alpha]_{\text{D}}^{20} = +15.7^\circ$, $c = 7.1 \times 10^{-3}$, D_2O) was virtually identical with that of authentic L-lysine hydrochloride ($[\alpha]_{\text{D}}^{20} = +16.0^\circ$, $c = 1.0 \times 10^{-2}$, D_2O). This established the absolute stereochemistry of C-10 as *S* in **7**.

Lactones **12** (Chart II) and **13** (Scheme I) were isolated as constituents of the crude oil, and their relationship to lactones **18** and **19**, obtained from the degradation of **7**, was demonstrated as follows. Conversion of **12** to **18**, **32**, or **13** was accomplished by using conditions which were respectively acetylation, reaction with 2,2-dimethoxypropane, or reaction with TSA. Analogously,

Scheme I

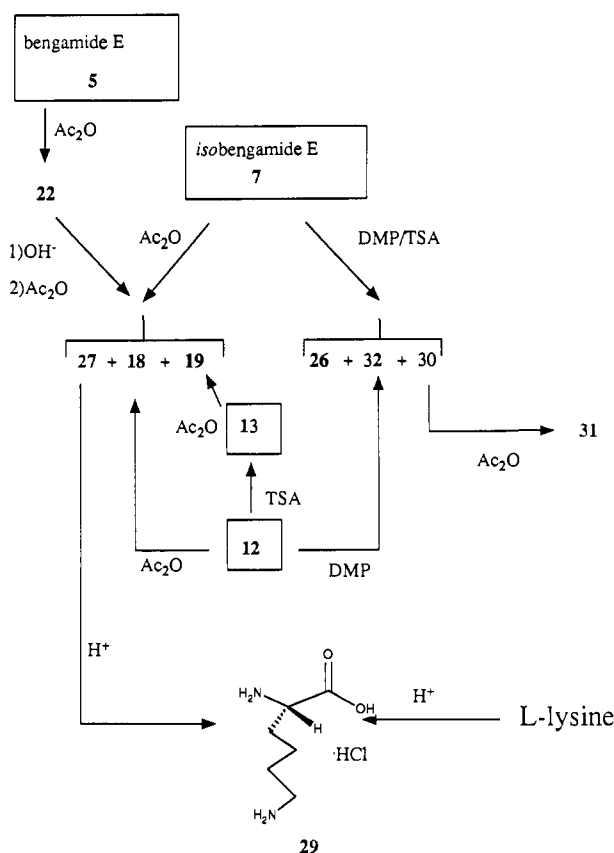

Chart II

H-H(J)	H-H (J) ^a				
	CDCl_3	MeOD	MeOD/ CD_3CN	cis	trans
2-3	4.5	4.2	4.2	4.5-5.7	8.5-8.9
3-4	3.0	2.7	2.7	2.8-3.0	8.2-8.6 0-0.7

^aRef. 6

13 was smoothly acetylated to **19**.

The relative stereochemistry of the four chiral centers of the C-10 side chain of isobengamide E was assigned by analysis of ^1H 3J values of compounds related to it as shown in Scheme I, including dioxolane **30**, dioxane lactone **32**, and the lactone **12**. Recently, we employed the characteristic J values at C-4/5 in a 1,3-dioxolane of 8.35–8.45 Hz for trans and 4.72–5.85 Hz for cis substitution to establish the stereochemistry of highly substituted dioxolanes.⁴ The dioxolane ring of **30** exhibited $J_{5-6} = 8.7$ Hz, which unambiguously indicated a trans relationship between these protons and, thus, a threo relationship between H-5 and H-6 in isobengamide E. The relative stereochemistry at the remaining three C's (6–8) could be decided from the analysis of the two lactones. A wealth of NMR J values are available from Serianni's extensive conformational analysis of aldono-1,4-lactones,⁶ and Chart II summarizes the variation of the J values as the proton stereochemistry changes at each ring position for nine compounds of structure *i* (Serianni's numbering). Also listed in Chart II are ^1H NMR J values, measured in three different solvents, for lactone

(5) Helmchen, G.; Nill, G.; Flockerzi, D.; Youssef, M. S. K. *Angew. Chem., Int. Ed. Engl.* **1979**, *18*, 63.

(6) Angelotti, T.; Krisko, M.; O'Connor, T.; Serianni, A. S. *J. Am. Chem. Soc.* **1987**, *109*, 4464.

Table I. ^1H NMR Data of Some of the Compounds Discussed (CDCl_3 , 300 MHz)

H no.	1			2			5			6		
	δ	mult	J , Hz	δ	mult	J , Hz	δ	mult	J , Hz	δ	mult	J , Hz
1	0.99	d	6.9	0.95	d	6.3	0.94	d	6.6	0.96	d	6.6
2	2.29	m		2.26	m		2.28	m		2.27	m	
3	5.78	dd	6.5, 15.5	5.72	dd	6.3, 15.6	5.73	dd	6.6, 15.6	5.74	dd	6.3, 15.3
4	5.44	dd	7.3, 15.5	5.40	dd	7.1, 15.6	5.40	dd	7.2, 15.6	5.42	dd	7.2, 15.6
5	4.21	t	6.0	4.17	t	6.0	4.17	dd	6.0, 6.3	4.18	dd	6.0, 6.3
6	3.60	brs		3.55	brd	5.1	3.59	brd	5.4	3.57	brd	5.4
7	3.80	m		3.76	brs		3.79	m		3.77	m	
8	3.80	m		3.76	brs		3.79	m		3.77	m	
9												
10	4.60	m		4.64	m		4.53	dd	6.9, 10.5	4.60	dd	6.6, 10.2
11	1.75	m		1.57	m		1.57	m		1.43	m	
	2.15	m		2.10	m		1.99	m		1.78	m	
12	1.95	m		1.95	m		1.80	m		1.78	m	
	2.15	m		2.10	m		1.99	m		1.97	m	
13	4.60	m		4.55	brt		1.34	m		1.43	m	
							1.80	m		1.78	m	
14	3.32	brm		3.18	brd	15.0	3.25	brm		3.18	dd	5.1, 15.3
				3.63	dd	9.9, 15.0				3.57	dd	11.4, 15.3
15	0.99	d	6.9	0.95	d	6.3	0.94	d	6.6	0.96	d	6.6
16												
17												
18	2.29	t	7.5	2.26	brt	7.5						
19	1.59	m		1.57	m							
20-27	1.4-1.2	brs	(20 H)	1.4-1.2	brs	(20 H)						
28	1.4-1.2	brs		1.4-1.2	brs							
29	1.4-1.2	brs		1.4-1.2	brs							
30	0.87	t	6.5	0.83	t	7.3						
N _a	7.97	d	6.3 (>90%)	7.92	d	6.0 (<10%)	7.92	d	6.6 (>95%)	7.92	d	6.3 (<5%)
	8.10	d	6.3 (<10%)	8.04	d	6.0 (>90%)	8.07	d	6.6 (<5%)	8.07	d	6.3 (>95%)
N _b	6.28	t	6.3				6.92	brs				
OH	4.27	brs		4.27	brs							
OMe	3.52	s		3.47	s		3.46	s		3.49	s	
NMe				3.05	s					3.00	s	

H no.	7 in MeOH- <i>d</i> ₄			14			15		
	δ	mult	J , Hz	δ	mult	J , Hz	δ	mult	J , Hz
1	0.98	d	6.9	1.00	d	6.6	1.00	d	6.6
2	2.26	oct	6.9	2.32	oct	6.6	2.32	oct	6.6
3	5.71	dd	6.5, 15.4	5.78	dd	6.3, 15.6	5.77	dd	6.3, 15.6
4	5.40	dd	7.2, 15.4	5.47	dd	7.2, 15.0	5.43	dd	7.2, 15.6
5	4.10	dd	6.6, 7.2	4.22	t	6.0	4.20	t	5.8
6	3.55	brd	6.6	3.65	m		3.67	m	
7	3.71	brs		3.80	m		3.79	m	
8	3.71	brs		3.80	m		3.79	m	
9									
10	4.13	m		4.61	m		4.59	m	
11	1.72	m		1.58	m		1.60	m	
	1.78	m		2.05	m		2.05	m	
12	1.98	m		1.85	m		1.85	m	
	2.04	m		2.05	m		2.20	m	
13	1.38	m		3.61	m		3.60	brt	
	1.83	m							
14	3.22	m		3.29	m		2.22	brd	13.2
							3.67	m	
15	0.98	d	6.9	1.00	d	6.6	1.00	d	6.6
16									
17									
18									
19									
20-27									
28									
29									
30									
N _a				7.98	d	6.0 (>90%)	8.07	d	6.0
				8.25	d	6.6 (<10%)			
N _b				6.16	brt				
OH									
OMe	3.37	s		3.54	s		3.51	s	
NMe							3.06	s	

12 (renumbered to correspond with i). The obvious conclusion reached by consideration of these data is that the ring H's are *all cis* in lactone **12**, which justifies the relative *6S**,*7R**,*8R** stereochemistry shown in **7**, and the previously assigned relative stereochemistry at C-5 can now be specified as *5R**. An additional

check on these assignments can be provided by the dioxane lactone **32** (see Chart III) because all four of these preceding chiral centers are now related through a bicyclic system. As expected, the ^1H $^3J_{7-8} = 3.9$ Hz of **32**, as compared to J values of model i (Chart II), indicates H-7 and H-8 are *cis*. The ^1H NMR J values that

Table II. ¹³C NMR Data of Some of the Compounds Discussed (CDCl₃, 75 MHz)^a

C no.	1		2		5		6		7 (MeOH-d ₄)		14		15	
	δ	mult	δ	mult	δ	mult	δ	mult	δ	mult	δ	mult	δ	mult
1	22.3	q*	22.2	q*	22.2	q*	22.2	q*	20.8	q*	22.2	q	22.2	q
2	30.9	d	30.7	d	30.8	d	30.8	d	30.2	d	30.9	d	30.9	d
3	141.9	d	141.6	d	141.6	d	141.7	d	140.2	d	142.0	d	141.9	d
4	125.5	d	125.4	d	125.5	d	125.4	d	125.7	d	125.4	d	125.4	d
5	74.3	d	74.1	d	74.1	d	74.2	d	73.5	d	74.4	d	74.3	d
6	72.5	d	72.5	d	72.7	d	72.5	d	70.7	d	72.4	d	72.5	d
7	72.8	d	72.5	d	72.4	d	72.7	d	72.9	d	72.9	d	72.8	d
8	81.3	d	81.1	d	81.7	d	81.0	d	82.4	d	81.0	d	81.1	d
9	172.3	s	171.8	s	171.7	s	171.7	s	174.1	s**	172.0	s	172.0	s
10	51.5	d	51.2	d	52.0	d	51.9	d	52.3	d	52.1	d	51.5	d
11	28.9	t	28.9	t	31.0	t	31.3	t	27.8	t***	28.9	t	29.2	t
12	33.0	t	32.6	t	28.0	t	27.7	t	28.3	t***	31.1	t	36.7	t
13	70.9	d	69.1	d	28.7	t	26.6	t	26.7	t***	70.7	d	67.9	d
14	45.2	t	53.3	t	42.0	t	50.4	t	40.4	t	42.2	t	56.4	t
15	22.2	q*	22.1	q*	22.1	q*	22.1	q*	20.7	q*	22.2	q	22.2	q
16	173.0	s	171.8	s	175.2	s	172.3	s	174.2	s**	172.0	s	172.0	s
17	174.2	s	173.0	s										
18	34.4	t	34.3	t										
19	25.0	t	24.8	t										
20-27	29.7-29.2	t	29.7-29.2	t										
28	32.0	t	31.9	t										
29	22.8	t	22.6	t										
30	14.2	q	14.1	q										
N _a														
N _b														
OH														
OMe	60.0	q	59.7	q	59.9	q	59.8	q	56.7	q	60.1	q	59.9	q
NMe			36.3	q			36.1	q					36.7	q

^a(*) Interchangeable.

Chart III

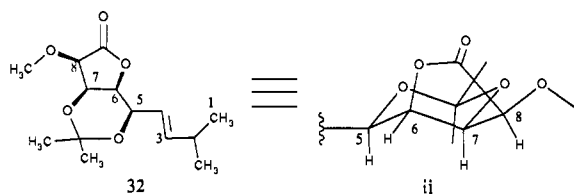

J (Hz)	CDCl ₃	DMSO	J (Hz)	1,3 dioxane ^a
7-8	3.9	3.6	aa	9.5 - 12.7
6-7	2.1	1.8	ae	2.0 - 5.6
5-6	2.1	~1	ee	1.1 - 2.3

^a Ref. 7

are characteristic of a 1,3-dioxane ring⁷ are summarized in Chart III. It was apparent that the small values of $J_{6-7} = 2.1$ Hz and $J_{5-6} = 2.1$ Hz of **32** did not allow any axial-axial relationships between the protons of the 1,3-dioxane ring. Hence, assuming that only chair conformations are reasonable, these protons necessarily must have either an axial-equatorial or equatorial-equatorial relationship relative to each other. This key limitation facilitated assigning conformer ii as the only possibility among the four diastereomers having a total of eight potential chair conformers. The complete set of all possible diastereomers can be most easily visualized by labeling them according to the stereochemistry of the vicinal H's H-5/6 and H-6/7 of structure ii in Chart III as cis/cis, and the others would be respectively trans/trans, trans/cis, and cis/trans. Three conformations (one from each of the latter three sets) can be ruled out because they have nonallowed axial-axial vicinal H relationships, three of the remaining five conformers have one or more non-hydrogen ring substituents in a 1,3-diaxial orientation and would ring flip to give a more stable conformer with at least one nonallowed axial-axial H, and the remaining two conformers belong to diastereomer ii. Thus, the stereochemistry across C-5/6 and C-6/7 must be all

cis, which is the same conclusion that was reached above from analysis of NMR data of **30** and **12**. In summary, the stereochemical relationships established above for isobengamide E are *S* at C-10 and 2(*R*^{*})-methoxy-3(*R*^{*}),4(*S*^{*}),5(*R*^{*})-trihydroxy-8-methyl-non-6(*E*)-enoyl for the amide side chain.

Initially, the data for bengamides C (**3**) and D (**4**), presented some perplexing anomalies. Immediately after their isolation, bengamide D was subjected to FAB mass spectral evaluation and the remaining sample of **4** and all of **3** were placed in CDCl₃ for NMR analysis. The positive ion FAB mass spectrum of bengamide D ($m/z = 619$, $M^+ + H$, $m/z = 641$, $M^+ + Na$) revealed the formula C₂₉H₅₀O₁₂N₂, and the diagnostic ¹H-¹³C COSY NMR signals analogous to bengamide A at C-10/H-10, C-11/H-11, C-8/H-8, and C-2/H-2 could all be located. However, the resonances for C-5-C-8 seemed to be "doubled" with the extra peaks identical in chemical shift to that of lactone **12**. The supposition that a fragmentation of bengamide D had occurred in CDCl₃, before an NMR spectrum could be obtained, to produce compound **15**, accompanied by lactone **12**, was demonstrated as being correct by subjecting the CDCl₃ sample of bengamide D to acetylation and then HPLC followed by MS and NMR analysis. A 1:1 mixture of **17** and **18** was isolated from HPLC and the extensive data obtained (see supplementary material and Table I) was consistent with their proposed structures. Parallel treatment of the CDCl₃ sample of bengamide C yielded a 1:1 mixture of **16** and **18** after HPLC. The equivalent behavior of **3** and **4** in the above sequence (to yield the homologues **16** and **17**) was especially important because it ruled out the possibility that the second C-10 side chain, present in bengamide C, could be attached at N-b, such as in isobengamide E (**7**). These collective observations indicated that by the time the original samples of bengamide C and D were analyzed by NMR they had literally been transformed into 1:1 mixtures of respectively **14** and **12**, and **15** and **12**. Thus, the NMR data presented in Tables I and II for respectively **14** and **15** were actually those measured on the solutions originally thought to contain respectively bengamides C and D.

The same stereochemistry of the amide side chain and C-10 in **7** could be shown to apply to the stereocenters of bengamides A-F, and the additional designation of *S* at C-13 was also elu-

(7) Eliel, E. L.; Knoeber, M. C., Sr. *J. Am. Chem. Soc.* **1968**, *90*, 3444.

cided for A–D as described below. Inspection of the ^{13}C NMR data revealed that the chemical shifts of the side-chain chiral carbons in respectively isobengamide E (7) and 1, 2, 5, 6, 14, and 15 were all within 2 ppm of one another. Also, a similar J value, $J \approx 16$, was observed across the C-3/4 double bond for all of these compounds. Treatment of bengamide F (6) with 2,2-dimethoxypropane and catalytic TSA in acetone afforded dioxolane 24, which was easily converted to the corresponding acetate 25. The ^1H NMR couplings between dioxolane ring H-5/6 protons of respectively 8.7 and 8.4 ppm indicated their relative trans stereochemistry by analogy to arguments developed above for assessing the stereochemistry within a 1,3-dioxane ring; consequently the $5R^*,6S^*$ relative stereochemistry could be assigned in bengamides A–F. Treatment of bengamide E triacetate (22) under basic hydrolysis conditions, followed by acetylation, afforded *N*-acetylcyclolysine (27), along with a 9:1 mixture of the lactones 18 and 19, which were each identical with the lactones whose stereochemistry was elucidated above. The stereochemical relationships established for these lactones enabled the $6S^*,7R^*,8R^*$ relative stereochemistry to be assigned in bengamides A–F. An acid-catalyzed conversion of 27 to *L*-lysine hydrochloride (29), prepared by previously described from *L*-lysine, allowed specification of the *S* absolute stereochemistry at C-10 for bengamides A–F.

Finally, a computer molecular modeling study was carried out on the hypothetical compounds *cis*- and *trans*-diacetyl- δ -hydroxylysine (28) using Still's MACROMODEL (version 1.5) molecular mechanics program.⁸ The goal was to compare the calculated vicinal ^1H J values of H-14 with those that could be measured for 2, 21, and 17. The calculated J values (dihedral angles) predicted for the minimum energy conformation of *cis*-28 ($E = 13.5$ kcal/mol) of 5.3 Hz (38°) and 1.6 Hz (75°) were different as compared to those calculated for the minimum energy conformation of *trans*-28 ($E = 10.4$ kcal/mol) of 9.8 Hz (166°) and 4.0 Hz (49°). Only the latter values closely matched those we observed for 2 (9.9 and ~ 3 Hz), 21 (10.0 and ~ 3 Hz), and 17 (10.2 and ~ 3 Hz), and these data enabled an *S* stereochemistry to be proposed at C-13 for bengamides A–D.

Two simple amino acid derivatives were isolated in small yield, and they were diketopiperazine 10 and *N*-acetylphenylalanine methyl ester (11). These compounds were initially identified from spectral data, and the configuration of all of their amino acids as *L* was shown by total chiral synthesis. By standard methodologies, 10 was prepared by coupling *L*-*trans*-4-hydroxyproline with an *L*-phenylalanine methyl ester, and 11 was prepared by acetylation of *L*-methoxyphenylalanine.

There are close analogies only to the very simple amino acids discovered in this study. Some years ago Schmitz⁹ isolated three diketopiperazines, *cyclo*(*L*-Pro-*L*-Leu), *cyclo*(*L*-Pro-*L*-Val), and *cyclo*(Pro-*L*-Ala), from the sponge *Tedania ignis*, and Pettit isolated *cyclo*(Gly-*L*-Pro) from the starfish *Luidia clathrata*.¹⁰ Recently, two diketopiperazine plant growth regulators, *cyclo*(*L*-*trans*-OH-Pro-*L*-Pro) and *cyclo*(*L*-*trans*-OH-Pro-*L*-Leu), were isolated from rabbit skin tissue. Another analogous compound may be baretin, a cyclic polypeptide of uncertain structure but composed of dehydro-6-bromotryptophane and proline, from *Geodia baretii*.¹¹

The suspicion exists that the bengamides are sponge symbiotic products because end-chain isopropyls, produced by terminal methyl branching, are characteristic of bacterial fatty acids.¹² They also appear to be of mixed ketide–amino acid biosynthetic

origin. Djerassi has conclusively shown that marine sponges utilize short-chain branched ketide precursors in the biosynthesis of long-chain branched fatty acids.¹³ Furthermore, it is also believed that biosynthetic subunits with terminal methyl groups can arise from the branched amino acids such as leucine.¹⁴ Thus, it seems attractive to consider that the bengamides arise by condensation of cyclized *L*-lysine¹⁵ with a diketide which unites with a six-carbon unit derived from leucine. These biosynthetic subunits are illustrated below for 7. From arguments too lengthy to explain here, the bengazoles appear also to be ketide amino acids that arise by routes which may be a hybrid of those proposed by Moore¹⁶ (for the ulapalides) and by ourselves for mycothiazole.¹⁷

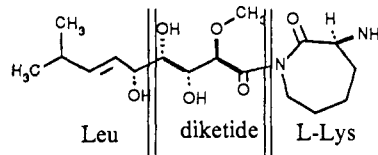

Experimental Section

The NMR spectra were recorded on a JEOL FX-100 PFT spectrometer (99.5 MHz for ^1H and 25.0 MHz for ^{13}C) or on a GN-300 spectrometer (300 MHz for ^1H and 75 MHz for ^{13}C). Multiplicities of ^{13}C NMR peaks were determined from APT or DEPT data, and COSY experiments were done on the GN-300. Mass spectrometry data were obtained on a Finnigan 4000 (6000 LS7 computer system) at UCSC. High-performance liquid chromatography (HPLC) was done on Waters μ -Porasil, Whatman Partisil, Rainin Microsorb C-18, or Regis 10 μ -ODS columns. All solvents were distilled and dried for HPLC use and were spectral grade for spectroscopy. Rotations were measured on a Perkin-Elmer 141 polarimeter.

Two-Dimensional NMR Procedures. Standard pulse sequences¹⁸ were used for the homo COSY (ref 18b, Figure 37) and the hetero COSY (ref 18b, Figure 35) experiments.

Isolation Procedures. The fresh *Jaspidae* sponge (13.7 kg wet weight) was cut into small pieces and soaked with MeOH for 24 h. The solvent was decanted and the oil concentrated to yield 14.07 g of crude viscous oil. A portion of the crude oil (~ 12 g) was then successively partitioned between equal volumes (500 mL) of aqueous MeOH (the composition was adjusted to produce a biphasic solution) and a solvent series of hexanes (4.5 g), CCl_4 (4.3 g), CH_2Cl_2 (2.7 g), and aqueous MeOH (0.4 g). The hexane, the CCl_4 , and the CH_2Cl_2 partition fractions were then separately chromatographed according to the regime shown in Chart I (supplementary material) and eventually yielded the following compounds. Hexanes: 13 (0.010 g), CCl_4 : 1 (0.012 g), 2 (0.004 g), 4 (0.018 g), 5 (0.005 g), 6 (0.027 g), 7 (0.012 g), 8 (0.043 g), 9 (0.038 g), 10 (0.021 g), 11 (0.004 g), 12 (0.068 g). CH_2Cl_2 : 3 (0.008 g), 5 (0.054 g), 6 (0.055 g), 8 (0.111 g), 9 (0.092 g), 10 (0.019 g).

Additional data for these compounds is as follows. **Bengamide D** (4). $[\alpha]_D^{20} = +19.8^\circ$ ($c = 8.6 \times 10^{-3}$, MeOH). FABMS, m/z : 641 [$\text{M}^+ + \text{Na}$ (14)], 619 [$\text{M}^+ + \text{H}$ (12)], 521 [619 – $\text{C}_6\text{H}_{11}\text{O} + \text{H}$ (36)], 461 [619 – $\text{C}_8\text{H}_{15}\text{O}_2 + \text{H}$ (38)], 389 [619 – $\text{C}_{11}\text{H}_{19}\text{O}_5 + \text{H}$ (38)]. **Bengamide E** (5). IR (neat): 3600–3200, 1660, 1650 cm^{-1} . $[\alpha]_D^{20} = +36.9^\circ$ ($c = 4.3 \times 10^{-2}$, MeOH). $\text{C}_{17}\text{H}_{30}\text{O}_6\text{N}_2$ HREIMS, m/z : 341.2078 [$\text{M}^+ - \text{OH}$ (1)], 291.1694 [$\text{M}^+ - \text{CH}_3\text{O} - 2\text{H}_2\text{O}$ (2)], 241.1188 [$\text{M}^+ - \text{C}_6\text{H}_{11}\text{O} - \text{H}_2\text{O}$ (100)]. LREIMS, m/z : 358 [M^+ (4)]. **Bengamide F** (6). IR (neat): 3600–3200, 1670, 1660 cm^{-1} . $[\alpha]_D^{20} = +27.9^\circ$ ($c = 0.039$, MeOH). $\text{C}_{18}\text{H}_{32}\text{O}_6\text{N}_2$ LRCIMS (CH_4), m/z : 373 [$\text{M}^+ + \text{H}$ (3)], 243 [$\text{C}_{11}\text{H}_{19}\text{O}_4\text{N}_2$ (24)]. **Isobengamide E** (7). $[\alpha]_D^{20} = +17.1^\circ$ ($c = 0.052$, MeOH). Oil, IR (neat): 3700–3200, 1650 cm^{-1} . LRCIMS (NH_3), m/z : 359 [$\text{M}^+ + \text{H}$ (3)], 231 [$\text{C}_{11}\text{H}_{18}\text{O}_5 + \text{H}$ (i.e. lactone 12) (36)], 230 [$\text{C}_{11}\text{H}_{18}\text{O}_5$ (i.e. lactone 12) (34)], 213 [230 – OH (35)], 174 [230 – C_4H_8 (47)], 157 [$\text{C}_7\text{H}_{11}\text{O}_2\text{N}_2 + 2\text{H}$ (89)], 143 [213 – $\text{C}_5\text{H}_6 - \text{H}$ (97)], 130 [$\text{C}_7\text{H}_{13}\text{O}_2 + \text{H}$ (100)], 129 [$\text{C}_6\text{H}_{12}\text{O}_2\text{N}_2 + \text{H}$ (99)], 83 [213 – $\text{C}_7\text{H}_{13}\text{O}_2 - \text{H}$ (9)], 58 [157 – $\text{C}_6\text{H}_{11}\text{O}$ (32)]. LREIMS, m/z : 358 [M^+ (2)].

(13) (a) Readerstorff, D.; Shu, A. Y.; Thompson, J. E.; Djerassi, C. D. *J. Org. Chem.* **1987**, *52*, 2337. (b) Carballera, N.; Thompson, J. E.; Ayanoglu, E.; Djerassi, C. D. *J. Org. Chem.* **1986**, *51*, 2751.

(14) See discussions in ref 13b and references within.

(15) There do not appear to be any simple examples of cyclolysines in the literature, and the closest analogy is the mycobactins characterized by Snow. For a recent total synthesis and references, see: Maurer, P. J.; Miller, M. J. *J. Am. Chem. Soc.* **1983**, *105*, 240.

(16) Ishibashi, M.; Moore, R. E.; Patterson, G. M. L.; Xu, C.; Clardy, J. *J. Am. Chem. Soc.* **1986**, *51*, 5300.

(17) Crews, P.; Kakou, Y.; Quiñoá, E. *J. Am. Chem. Soc.* **1988**, *110*, 4365.

(18) For reviews, see: (a) Shooley, J. N. *J. Nat. Prod.* **1984**, *47*, 226. (b) Benn, R.; Günther, H. *Angew. Chem.* **1983**, *22*, 350.

(8) Still, W. C.; MacPherson, L. J.; Harada, T.; Callahan, J. F.; Rheingold, A. L. *Tetrahedron* **1984**, *40*, 2275.

(9) Schmitz, F. J.; Vanderah, D. J.; Hollenbeak, K. H.; Enwall, C. E.; Gopichand, Y.; SenGupta, P. K.; Hossain, M. B.; van der Helm, D. *J. Org. Chem.* **1983**, *48*, 3941.

(10) Pettit, G. R.; VonDreele, R. B.; Bolliger, G. B.; Traxler, P. M.; Brown, P. *Experientia* **1973**, *29*, 521.

(11) The original proposed structure (Lidgren, G.; Bohlin, L.; Bergman, J. *Tetrahedron Lett.* **1986**, *27*, 3283) is incorrect: Lieberknecht, A.; Griesser, H. *Tetrahedron Lett.* **1987**, *28*, 4275.

(12) Nes, W. R.; Nes, W. D. *Lipids in Evolution*; Plenum: New York, 1980; pp 88–142.

Fragmentation of Bengamide C (3) to 14 and 12. Compound 3, which was isolated as a single peak by HPLC, was placed in a NMR tube with CDCl_3 , and after 2 h the NMR spectrum showed that the original compound had become a mixture of two compounds (in a ratio of 1:1) namely the lactone **12** and bengamide **14** (Tables I and II).

Fragmentation of Bengamide D (4) to 15 and 12. Bengamide D fragmented in a manner similar to that of bengamide C to afford a 1:1 mixture of lactone **12** and bengamide **15**: LRCIMS (CH_4), m/z 389 [$\text{M}^+ + \text{H}$ (15)].

Ketalization of Isobengamide E (7). 2,2-Dimethoxypropane (1.5 mL) and a catalytic amount of *p*-toluenesulfonic acid was added to a 5-mg sample of isobengamide E (7) in 1.5 mL of dry acetone. The reaction mixture was allowed to stand under nitrogen at room temperature for 24 h. After the mixture was neutralized with aqueous NaHCO_3 and extracted with CH_2Cl_2 (3×5 mL), the combined organic layers were concentrated to dryness (temperature below 40°C) in vacuo to yield a 4:1 mixture of **30** and **32**, respectively; 68% total yield after purification via reverse-phase HPLC (solvent = $\text{MeOH}/\text{H}_2\text{O}$ 90:10). The aqueous layer was likewise concentrated in vacuo and purified via reverse-phase HPLC (solvent = $\text{MeOH}/\text{H}_2\text{O}$ 85:15) to afford **26** in 45% yield. **30**: IR (neat): 3550–2500, 1720 cm^{-1} . NMR (CDCl_3) shifts in ppm from Me_4Si [atom number], ^1H δ and J values at 300 MHz: [1] 1.00 (d, $J = 6.6$ Hz, Me); [2] 2.33 (oct, $J = 6.6$); [3] 5.83 (dd, $J = 15.6, 6.6$ Hz); [4] 5.37 (dd, $J = 15.6, 7.8$ Hz); [5] 4.39 (dd, $J = 8.7, 7.8$ Hz); [6] 3.87 (dd, $J = 8.7, \sim 1$ Hz); [7] 3.73 (dd, $J = 7.2, \sim 1$ Hz); [8] 3.84 (d, $J = 7.2$ Hz); [15] 0.99 (d, $J = 6.6$ Hz, Me); [18] 1.45 (s, Me); [19] 1.43 (s, Me); [OMe] 3.50 (s, 3 H). LREIMS, m/z : 288 [M^+ (8)]. LRCIMS (NH_3), m/z : 289 [$\text{M}^+ + \text{H}$ (4)]. **26**: NMR ($\text{MeOH}-d_4$) shifts in ppm from Me_4Si [atom number], ^1H δ s and J s at 300 MHz: [10] 4.63 (br d, $J = 11.7$ Hz); [11–13] 1.33–2.00 (6 H); [14] 3.21 (m, 2 H). LRCIMS (NH_3), m/z : 129 [$\text{M}^+ + \text{H}$ (5)]. **32**: IR (neat): 1770 cm^{-1} . NMR (CDCl_3) shifts in ppm from Me_4Si [atom number], ^1H δ and J values at 300 MHz: [1] 1.01 (d, $J = 6.6$ Hz, Me); [2] 2.34 (oct, $J = 6.3$ Hz); [3] 5.83 (dd, $J = 15.3, 6.3$ Hz); [4] 5.62 (ddd, $J = 15.3, 7.2, 1.2$ Hz); [5] 4.45 (dd, $J = 7.2, 2.1$ Hz); [6] 3.99 (dd, $J = 2.1, 2.1$ Hz); [7] 4.71 (dd, $J = 3.9, 2.1$ Hz); [8] 4.09 (d, $J = 3.9$ Hz); [11] 1.53 (s, Me); [12] 1.49 (s, Me); [15] 1.01 (d, $J = 6.6$ Hz, Me); [OMe] 3.67 (s, 3 H). HREIMS, m/z 269.13880, $\text{C}_{14}\text{H}_{21}\text{O}_5$ ($\text{M}^+ - \text{H}$), requires 269.13893. LRCIMS (NH_3), m/z : 271 [$\text{M}^+ + \text{H}$ (5)].

Acetylation of Isobengamide E (7). As in a prescribed manner (see supplementary material), a solution of **7** (5 mg) was acetylated. After being concentrated in vacuo, the reaction mixture was chromatographed via reverse-phase HPLC ($\text{MeOH}/\text{H}_2\text{O}$ 50:50) to afford **18** and **19**, respectively, in 82% overall yield and in a 9:1 ratio, along with **27** in 74% yield. **27**: $[\alpha]_D^{20} = +54.9^\circ$ ($c = 2 \times 10^{-3}$, CHCl_3). IR (neat): 1660, 1650 cm^{-1} . NMR (CDCl_3) shifts in ppm from Me_4Si [atom number], ^{13}C δ values at 75 MHz, ^1H δ and J values at 300 MHz: [10] 52.3, 4.52 (ddd, $J = 10.8, 5.7, 1.2$ Hz); [11, 12, 13] 31.7*, 28.0*, 29.0*, 1.3–2.2 (6 H); [14] 42.3, 3.26 (m, 2 H); [16] 175.6; [NH_4] 6.87 (br s); [NH_2] 5.98 (br s); [Ac] 23.4, 169.3, 2.01 (s, 3 H). HREIMS, m/z 170.10570, $\text{C}_8\text{H}_{14}\text{O}_2\text{N}_2$, requires 170.10562. LRCIMS (NH_3), m/z : 171 [$\text{M}^+ + \text{H}$ (100)]. **18**: $[\alpha]_D^{20} = -14.9^\circ$ ($c = 2.64 \times 10^{-2}$, CHCl_3). IR (neat): 3600–3100, 1770 cm^{-1} . NMR (CDCl_3) shifts in ppm from Me_4Si [atom number], ^{13}C δ and ^1H δ values at 300 MHz: [1] 21.9, 0.94 (d, $J = 6.6$ Hz, Me); [2] 31.0, 2.27 (oct, $J = 6.6$ Hz); [3] 147.0, 5.86 (dd, $J = 15.6, 6.6$ Hz); [4] 118.4, 5.19 (ddd, $J = 15.3, 7.8, 1.2$ Hz); [5] 72.8, 5.53 (dd, $J = 9.0, 7.8$ Hz); [6] 78.1, 4.47 (dd, $J = 9.0, 3.3$ Hz); [7] 68.4, 5.64 (dd, $J = 4.5, 3.3$ Hz); [8] 77.7, 4.10 (d, $J = 4.5$ Hz); [9] 171.4; [15] 21.5, 0.95 (d, $J = 6.9$ Hz, Me); [OMe] 60.2, 3.54 (s, 3 H); [OAc] 169.6, 169.3, 21.2, 20.7, 2.07 (s, 3 H), 2.12 (s, 3 H). HREIMS, m/z : 314.14830, $\text{C}_{15}\text{H}_{22}\text{O}_7$, requires 314.13656. LREIMS, m/z : 314 [M^+ (21)], 272 [$\text{M}^+ - \text{C}_3\text{H}_7 + \text{H}$ (3)], 254 [$\text{M}^+ - \text{AcOH}$ (2)], 225 [$\text{M}^+ - \text{C}_4\text{H}_8 - \text{MeOH}$ (11)], 183, [254 - $\text{C}_3\text{H}_9 - 2\text{H}$ (67)], 141 [$\text{C}_8\text{H}_{13}\text{O}_2$ (100)], 129 [183 - $\text{C}_4\text{H}_8 + 2\text{H}$ (34)], 114 [183 - C_3H_9 (14)], 99 [141 - Ac + H (47)], 81 [141 - AcOH (17)]. LRCIMS (NH_3), m/z : 332 [$\text{M}^+ + \text{NH}_4$ (43)], 315 [$\text{M}^+ + \text{H}$ (11)], 272 [$\text{M}^+ - \text{C}_3\text{H}_7 + \text{H}$ (45)]. **19**: NMR (CDCl_3) shifts in ppm from Me_4Si [atom number], ^1H δ values at 300 MHz: [1] 0.99 (d, $J = 6.6$ Hz, Me); [2] 2.31 (oct, $J = 6.6$ Hz); [3] 5.85 (dd, $J = 14.4, 6.3$ Hz); [4] 5.40 (dd, $J = 14.4, 7.8$ Hz); [5] 5.37 (br d, $J = 6.9$ Hz); [6] 4.97 (br d, $J = 2.4$ Hz); [7] 5.95 (d, $J = 1.8$ Hz); [15] 0.99 (d, $J = 6.6$ Hz, Me); [OMe] 3.80 (s, 3 H); [OAc] 2.06 (s, 3 H). HREIMS, m/z 254.11430, $\text{C}_{13}\text{H}_{18}\text{O}_5$, requires 254.11544. LRCIMS (NH_3), m/z : 272 [$\text{M}^+ + \text{NH}_4^+$ (100)], 255 [$\text{M}^+ + \text{H}$ (1)], 212 [255 - C_3H_7 (2)], 195 [255 - HOAc (2)]. LREIMS, m/z : 255 [$\text{M}^+ + \text{H}$ (1)], 212 [255 - C_3H_7 (2)], 195 [255 - HOAc (10)], 163 [195 - MeOH (4)], 156 [212 - C_4H_8 (43)], 141 [$\text{C}_8\text{H}_{13}\text{O}_2$ (83)], 114 [$\text{C}_5\text{H}_5\text{O}_3 + \text{H}$ (100)], 99 [212 - $\text{C}_5\text{H}_5\text{O}_3$ (78)], 81 [141 - HOAc (30)].

cyclo (L-Phenylalanine-trans-4-hydroxy-L-proline) (10): viscous oil $[\alpha]_D^{20} = -6.7^\circ$ ($c = 1.6 \times 10^{-2}$, MeOH). IR (CDCl_3) 3300–3500, 3100–3200, 1650–1750 cm^{-1} . NMR (CDCl_3) shifts in ppm from Me_4Si ,

assignments as described above, [atom number], ^{13}C δ values at 75 MHz, ^1H δ and J values at 300 MHz: [2] 169.8; [3] 56.2, 4.31 (dd, $J = 10.7, 2.6$ Hz); [NH] 5.89 (s); [5] 166.2; [6] 57.4, 4.47 (dd, $J = 11.1, 6.3$ Hz); [7] 37.7, 2.06 (ddd, $J = 13.5, 11.4, 4.2$ Hz), 2.36 (dd, $J = 13.2, 6.2$ Hz); [8] 68.2, 4.60 (t, $J = 4.1$ Hz); [9] 54.4, 3.58 (d, $J = 13.8$ Hz), 3.80 (dd, $J = 13.2, 4.5$ Hz); [10] 36.7, 2.77 (dd, $J = 14.6, 10.9$ Hz), 3.63 (dd, $J = 15.9, 3.9$ Hz); [11] 135.8; [12, 12'] 129.3, 7.29 (br m); [13, 13'] 129.2, 7.29 (br m); [14] 127.6, 7.29 (br m). FABMS, m/z : 261 [$\text{M}^+ + \text{H}$ (100)], 227 [261 - 2 OH (30)], 185 [$\text{C}_8\text{H}_{11}\text{N}_2\text{O}_3 + 2\text{H}$ (35)], 169 [$\text{C}_7\text{H}_9\text{N}_2\text{O}_3$ (16)], 170 [$\text{C}_7\text{H}_9\text{N}_2\text{O}_3 + \text{H}$ (14)], 171 [$\text{C}_7\text{H}_9\text{N}_2\text{O}_3 + 2\text{H}$ (16)], 143 [$\text{C}_6\text{H}_7\text{NO}_3 + 2\text{H}$ (12)], 141 [$\text{C}_6\text{H}_7\text{NO}_3$ (10)].

N-Acetyl-L-phenylalanine methyl ester (11): viscous oil, $[\alpha]_D^{20} = +27.0^\circ$ ($c = 2 \times 10^{-2}$, CHCl_3). NMR (CDCl_3) shifts in ppm from Me_4Si [atom number], ^1H δ and J values at 300 MHz: [2] 4.90 (dd, $J = 13.5, 7.0$ Hz); [3] 3.09 (dd, $J = 13.9, 6.2$ Hz), 3.18 (dd, $J = 13.9, 7.3$ Hz); [5–9] 7.20 (m); [NH] 5.90 (d, $J = 6.6$ Hz); [OMe] 3.73 (s, 3 H); [Ac] 1.99 (s, 3 H). LRCIMS (NH_3), m/z : 221 [M^+ (14)], 57 [NHCOCH₃ - H (100)]. LREIMS, m/z : 221 [M^+ (5)], 162 [$\text{M}^+ - \text{NHCOCH}_3 - \text{H}$ (100)].

Hydrolysis of 27 (from 7). A solution of **27** (2 mg) in 6 M HCl (2 mL) was refluxed for 5.5 h. Additional 6 M HCl was added during the course of the reaction so as to maintain a constant pH. The reaction mixture was next concentrated to dryness in vacuo and the hydrolyzed product was obtained in quantitative yield. Likewise, authentic samples of L-lysine and D-lysine were each treated with 6 M HCl to afford their respective salts and the ^1H NMR, MS, and optical rotation data were in accord with those expected for their structures.

3,5-Dihydroxy-2-methoxy-8-methylnon-6-ene 1,4-Lactone (12). IR (neat): 3600–3100, 1770 cm^{-1} . NMR (CDCl_3) shifts in ppm from Me_4Si [atom number], ^{13}C δ values at 75 MHz, ^1H δ and J values at 300 MHz: [1] 22.2, 1.00 (d, $J = 6.9$ Hz, Me); [2] 30.9, 2.33 (oct, $J = 6.6$ Hz); [3] 142.3, 5.95 (ddd, $J = 15.6, 6.6, 0.6$ Hz); [4] 122.9, 5.53 (ddd, $J = 15.6, 6.6, 0.9$ Hz); [5] 70.5, 4.60 (dd, $J = 7.2, 6.6$ Hz); [6] 82.7, 4.10 (dd, $J = 3.0, 7.2$ Hz); [7] 68.4, 4.47 (dd, $J = 4.2, 3.0$ Hz); [8] 78.9, 4.09 (d, $J = 4.5$ Hz); [9] 173.4; [15] 22.2, 1.00 (d, $J = 6.9$ Hz, Me); [OMe] 59.2, 3.68 (s, 3 H). LRCIMS (NH_3), m/z : 265 [$\text{M}^+ + \text{N}_2\text{H}_4$ (11)], 248 [$\text{M}^+ + \text{NH}_4$ (100)], 231 [$\text{M}^+ + \text{H}$ (15)], 230 [M^+ (48)], 213 [$\text{M}^+ - \text{OH}$ (22)], 185 [$\text{M}^+ - \text{C}_3\text{H}_7 - 2\text{H}$ (14)], 169 [185 - OH + H (26)], 143 [213 - $\text{C}_5\text{H}_9 - \text{H}$ (10)], 129 [185 - C_4H_8 (8)], 85 [185 - $\text{C}_6\text{H}_{11}\text{O} - \text{H}$ (5)], 58 [$\text{C}_4\text{H}_8 + 2\text{H}$ (5)], 52 [85 - MeOH - H (11)].

Ketalization of 12. In the same manner as previously described, a solution of **12** (7 mg) was reacted with 2,2-dimethoxypropane and TSA in acetone to afford the dioxolane **32** in 68% overall yield (from the combined organics).

3,5-Dihydroxy-2-methoxy-8-methylnona-2,6-diene 1,4-Lactone (13). IR (neat): 3600–3100, 1750 cm^{-1} ; NMR (CDCl_3) shifts in ppm from Me_4Si [atom number], ^{13}C δ values at 75 MHz, ^1H δ and J values at 300 MHz: [1] 22.2, 1.00 (d, $J = 6.9$ Hz, Me); [2] 31.0, 2.32 (oct, $J = 6.6$ Hz); [3] 143.8, 5.82 (dd, $J = 15.6, 6.6$ Hz); [4] 123.1, 5.41 (ddd, $J = 15.3, 6.6, 0.9$ Hz); [5] 74.5, 4.08 (dd, $J = 6.6, 6.3$ Hz); [6] 81.4, 4.84 (dd, $J = 6.3, 1.8$ Hz); [7] 113.1, 5.97 (d, $J = 1.8$ Hz); [8] 148.2; [9] 167.2; [15] 22.1, 1.00 (d, $J = 6.9$ Hz, Me); [OMe] 58.2, 3.80 (s, 3 H). LRCIMS (isobutane), m/z : 213 [$\text{M}^+ + \text{H}$ (100)], 195 [213 - H_2O (100)], 181 [213 - MeOH (73)], 115 [$\text{M}^+ + \text{H} - \text{C}_7\text{H}_{12}\text{O}$ (43)], 99 [$\text{C}_6\text{H}_{11}\text{O}$ (39)], 81 [99 - H_2O (8)], 71 [114 - C_3H_7 (8)]. LREIMS, m/z : 213 [$\text{M}^+ + \text{H}$ (2)], 195 [$\text{M}^+ + \text{H} - \text{H}_2\text{O}$ (1)], 114 [$\text{M}^+ - \text{C}_6\text{H}_{11}\text{O}$ (99)], 99 [$\text{C}_6\text{H}_{11}\text{O}$ (100)], 81 [99 - H_2O (68)], 71 [114 - C_3H_7 (44)], 57 [114 - $\text{C}_4\text{H}_8 + \text{H}$ (61)].

Preparation of Dioxolane 24. 2,2-Dimethoxypropane (2.0 mL) and a catalytic amount of *p*-toluenesulfonic acid were added to a 12-mg sample of bengamide F (**6**) in 2.0 mL of acetone. The reaction mixture was allowed to stand under nitrogen at room temperature for 24 h. After the mixture was neutralized with aqueous NaHCO_3 and extracted with CH_2Cl_2 (3×5 mL), the combined organic layers were concentrated to dryness (temperature below 40°C) in vacuo to afford **24** in 88% yield; after HPLC 30% remained (aqueous MeOH). **24**: The NMR (CDCl_3) shifts in ppm from Me_4Si are provided and the assignments were determined by $^1\text{H}-^1\text{H}$ COSY data, [atom number], ^1H δ and J values at 300 MHz: [1] 0.99 (d, $J = 6.6$ Hz); [2] 2.30 (dsep, $J = 6.6, 6.3$ Hz); [3] 5.81 (dd, $J = 15.3, 6.3$ Hz); [4] 5.36 (ddd, $J = 15.3, 8.4, 1.2$ Hz); [5] 4.48 (dd, $J = 8.7, 8.4$ Hz); [6] 3.84 (dd, $J = 8.7, 1.2$ Hz); [7] 3.58 (dd, $J = 8.7, 1.2$ Hz); [8] 3.70 (d, $J = 8.7$ Hz); [10] 4.64 (ddd, $J = 10.8, 6.3, 1.2$ Hz); [11–13] 1.4–2.1 (m, 6 H); [14] 3.20 (dd, $J = 15.3, 5.4, 1.0$ Hz), 3.59 (br dd, $J = 15.3, 12.0$ Hz); [15] 0.98 (d, $J = 6.6$ Hz); [18] 1.43 (s, Me); [19] 1.43 (s, Me); [NH] 7.99 (d, $J = 6.3$ Hz); [OMe] 3.50 (s, 3 H); [NMe] 3.04 (s, 3 H). LREIMS, m/z : 412 [M^+ (13)].

Hydrolysis of Bengamide E Acetate (22). A solution of **22** (8 mg) in 1% MeOH/KOH was refluxed for 1 h. Next, the reaction mixture was concentrated to dryness in vacuo (less than 40°C). Acetic anhydride (5 mL) was added to the residue and the mixture stirred for 36 h at room

temperature. The mixture was partitioned between H₂O (5 mL) and CH₂Cl₂ (3 × 5 mL). The combined organic extracts were dried over anhydrous MgSO₄, filtered, and concentrated to dryness, in vacuo, and the residue was chromatographed via reverse-phase HPLC (MeOH/H₂O 35:65) to afford **18** and **19** (in a ratio of 9:1) in 62% overall yield and **27** in 84% yield.

Hydrolysis of 27 (from 22). A solution of **27** (5 mg) in 6 M HCl (3 mL) was refluxed for 5 h. Additional HCl was added during the course of the reaction to maintain a constant pH. The reaction mixture was concentrated to dryness, in vacuo, and **29** was obtained in 100% yield.

L-Lysine hydrochloride (29): $[\alpha]_D^{20} = +15.7^\circ$ ($c = 0.007$, D₂O). NMR (D₂O) shifts in ppm from Me₄Si, ¹H δ and J values at 300 MHz: 4.04 (t, $J = 6.0$ Hz, 1 H); 2.98 (t, $J = 7.1$ Hz, 2 H); 1.94 (m, 2 H); 1.69 (t, $J = 7.2$ Hz, 2 H); 1.50 (m, 2 H). LRCIMS (NH₃) m/z : 147 [M⁺ + H (3)].

Acknowledgment. Partial research support was from NOAA, National Sea Grant College Program, Department of Commerce,

University of California, project number R/MP-41. The U.S. Government is authorized to produce and distribute reprints for governmental purposes. Other grant support was from Syntex Inc., and the University Research Expeditions Program supported field work in Fiji. We are grateful for the cooperation of the Fiji Government. We thank Jim Loo (UCSC) for assistance with NMR measurements and Janette Talbot for assistance with some of the isolation work, and valuable assistance in sponge collection came from Cal Ponzini and Lisa Hunter.

Supplementary Material Available: Additional NMR data of compounds **7**, **11-13**, **15**, **24**, **27**, **32**; acetylation reactions of compounds **1**, **2**, **5**, **6**, **12-15**, **24**, **30**; the dehydration of **12**; the synthesis of **10** and **11**; ¹H NMR data of compounds **16**, **17**, **20-23**; and the chromatographic operations performed on the solvent-partition fractions (Chart I) (10 pages). Ordering information is given on any current masthead page.

Directed Ortho-Lithiation of Lithium Thiophenolate. New Methodology for the Preparation of Ortho-Substituted Thiophenols and Related Compounds

Garret D. Figuly, Cynthia K. Loop, and J. C. Martin*¹

Contribution from the Department of Chemistry, University of Illinois, Urbana, Illinois 61801, and the Department of Chemistry, Vanderbilt University, Nashville, Tennessee 37235.

Received March 14, 1988

Abstract: The directed ortho-lithiation of lithium thiophenolate by reaction with *n*-butyllithium in cyclohexane with *N,N,N',N'*-tetramethylethylenediamine gives almost quantitative conversion to lithium 2-lithiobenzenethiolate (**1**). Reactions of this dilithio derivative with a variety of electrophiles (D₂O, carbon dioxide, acetone, diphenyl disulfide, methyl iodide, and thioxanthone) are described. The adduct to thioxanthone is ring-closed to form a triarylmethyl cation (**9**), and its related carbinol (**8**), with two *o,o'*-sulfide bridges.

Research in the field of ortho-directed aromatic metalations² has included studies of ortho-directing substituents that undergo side-chain metalation prior to ring ortho-metalation to give dimetalated species.³ A method for ortho-lithiation of lithium phenolate has been developed by Posner.^{2b} There has been,

however, little prior research reported on the ortho-metalation of thiophenol. Gilman reported low-yield dilithiation of monobromothiophenols via halogen-metal exchange.^{4b} Work in our laboratories failed to improve these methods.^{4c} Related research on the ortho-lithiation of alkylthioarenes has been done.^{4e} As a part of our continuing search for new sulfur-containing synthetic intermediates we here report a very efficient and useful method for the direct ortho-lithiation of lithium thiophenolate. Recent work, described in adjacent papers by Eric Block et al.^{5a} and Keith Smith et al.,^{5b} has established a number of interesting applications of this lithiation and interesting modified versions of this lithiation technique.

Experimental Section

General Procedures. Proton and carbon NMR spectra were obtained from CDCl₃ solutions unless otherwise noted and chemical shifts are reported (ppm) downfield from tetramethylsilane internal standard. The COSY NMRs were obtained on a 200.057-MHz Varian instrument.⁶

(1) Figuly, G. D. Ph.D. Thesis, University of Illinois, 1981. Current address of J.C.M., Vanderbilt University; G.D.F., Experimental Station, Du Pont Co., Wilmington, DE 19898.

(2) For discussions and reviews, see: (a) Gschwend, H. W.; Rodriguez, H. R. *Org. React.* **1979**, *26*, 1. (b) Abicht, H. P.; Issleib, K. Z. *Chem.* **1977**, *17*, 1-9. (c) Slocum, D. W.; Jennings, C. A. *J. Org. Chem.* **1976**, *41*, 3653-3664. (d) Mallan, J. M.; Bebb, R. L. *Chem. Rev.* **1969**, *69*, 693. (e) Wakefield, B. J. *The Chemistry of Organolithium Compounds*; Pergamon Press: New York, 1974; Chapter 3. (f) Beak, P.; Snieckus, V. *Acc. Chem. Res.* **1982**, *15*, 306. (g) Beak, P.; Meyers, A. I. *Ibid.* **1986**, *19*, 356. (h) Posner, G. H.; Canella, K. A. *J. Am. Chem. Soc.* **1985**, *107*, 2571-2573.

(3) Related dimetalations include those of: (a) Arenesulfonic acids: Figuly, G. D.; Martin, J. C. *J. Org. Chem.* **1980**, *45*, 3728-3729. Stoyanovich, F. M.; Gof'dfarb, Y. L.; Marakatkina, M. A.; Karpenko, R. G. *Izv. Akad. Nauk. SSSR, Ser. Khim.* **1980**, *1*, 145. (b) Benzyl alcohols: Gilman, H.; Brown, G. E.; Webb, F. J.; Spatz, S. M. *J. Am. Chem. Soc.* **1940**, *62*, 977-979. Uemura, M.; Tokuyama, S.; Sakan, T. *Chem. Lett.* **1975**, 1195. Martin, J. C.; Balthazor, T. M. *J. Am. Chem. Soc.* **1977**, *99*, 152-162. Meyer, N.; Seebach, D. *Angew. Chem., Int. Ed. Engl.* **1978**, *17*, 521. Perozzi, E. F.; Martin, J. C. *J. Am. Chem. Soc.* **1979**, *101*, 1591-1593. Perozzi, E. F.; Michalak, R. S.; Figuly, G. D.; Stevenson, W. H., III; Dess, D. B.; Ross, M. R.; Martin, J. C. *J. Org. Chem.* **1981**, *46*, 1049-1053. (c) Aryl amides: Marxer, A.; Rodriguez, H. R.; McKenna, J. M.; Tsai, H. M. *J. Org. Chem.* **1975**, *40*, 1427-1433. Baldwin, J. E.; Bair, K. W. *Tetrahedron Lett.* **1979**, 2559, and references therein. (d) Thioamides: Fitt, J. J.; Gschwend, H. W. *J. Org. Chem.* **1976**, *41*, 4029-4031. (e) Sulfonamides: Watanabe, H.; Gay, R. L.; Hauser, C. R. *J. Org. Chem.* **1968**, *33*, 900-903. (f) Isonitriles: Walborsky, H. M.; Ronman, P. *J. Org. Chem.* **1978**, *43*, 731-734. (g) Anilides: Fuhrer, W.; Gschwend, H. W. *J. Org. Chem.* **1979**, *44*, 1133-1136. (h) Sulfonylhydrazones: Chamberlin, A. R.; Stemke, J. E.; Bond, F. T. *J. Org. Chem.* **1978**, *43*, 147-154.

(4) (a) See ref 1 and 2 for the lack of mention of the ortho-metalation of thiophenol. (b) For work done concerning the dimetalation of 2-halothiophenols, see: Gilman, H.; Gainer, G. C. *J. Am. Chem. Soc.* **1947**, *69*, 877-880. Jones, R. G.; Gilman, H. *Org. React.* **1951**, *6*, 339. (c) For work done in our laboratories using methods similar to Gilman, see: Yamaye, M. Ph.D. Thesis, University of Illinois, Urbana, IL, 1971. (d) For unsuccessful attempts to ortho-lithiate thiophenol, see: Peters, N. J. Ph.D. Thesis, University of Illinois, Urbana, IL, 1980. (e) Or *S*-alkylthiophenols: Lockyer, T. N. *Aust. J. Chem.* **1974**, *27*, 259. Workman, M. O.; Dyer, G.; Meek, D. W. *Inorg. Chem.* **1967**, *6*, 1543. Horner, L.; Lawson, A. J.; Simons, G. *Phosphorus Sulfur* **1982**, *12*, 353.

(5) (a) Block, E.; Eswarakrishnan, V.; Gernon, M.; Kang, H.; Ofori-Okai, G.; Saha, C.; Tang, K.; Zubieta, J. *J. Am. Chem. Soc.*, following paper in this issue. (b) Smith, K.; Lindsay, C.; Pritchard, G. *Ibid.*, following ref. 5a in this issue.